

BRACKET FOR WALL MOUNTING

This accessory is used to mount 45mm wide MiniLine-2 power supplies or PISA11 protection modules on a wall or on a panel without using a DIN-Rail.

INSTALLATION

Fig. 1 **Installation**

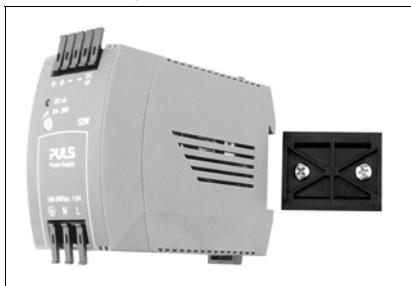

Mount the bracket on the wall and click the unit onto the rail

MECHANICAL DIMENSIONS

Fig. 2 **Mounting dimensions**

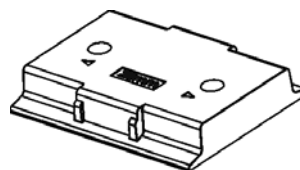
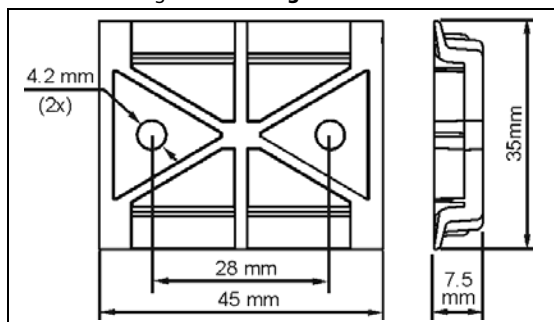

ORDER NUMBER

ZM3.WALL Bulk-package with 25 pcs.

The information presented in this document is believed to be accurate and reliable and may change without notice. No part of this document may be reproduced or utilized in any form without permission in writing from the publisher.